

CAD FILE:

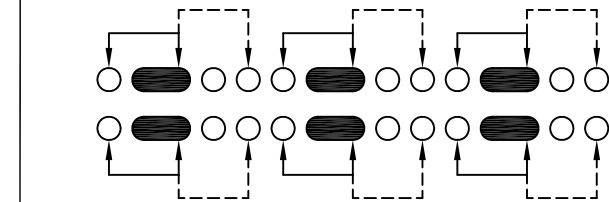

SCHEMATIC (NOT SPECIFIED)

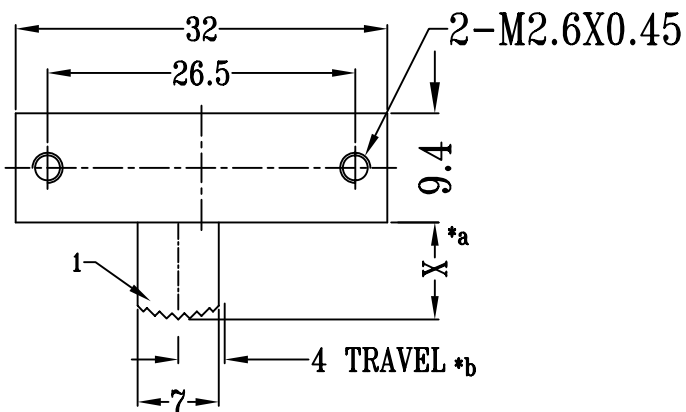
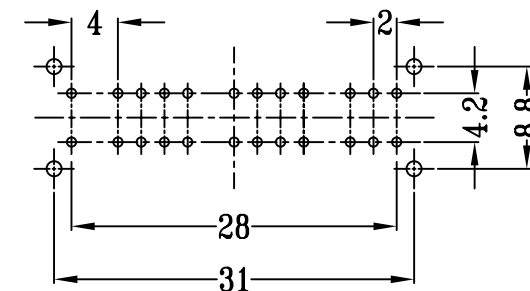
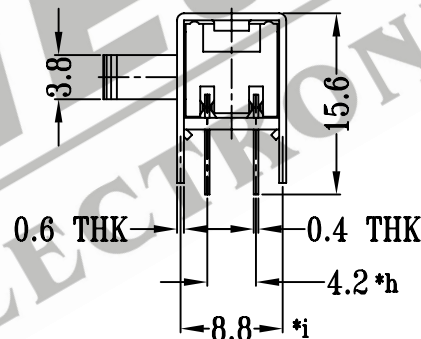
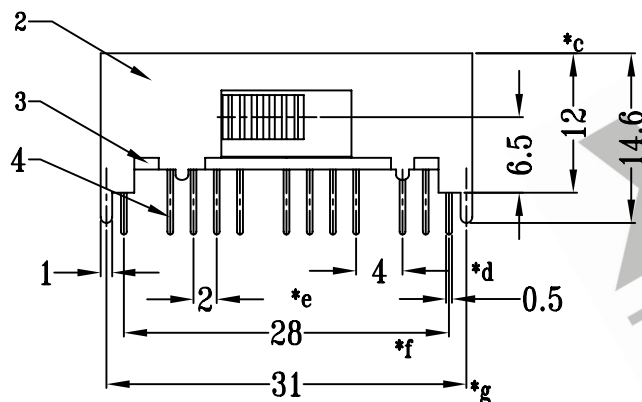

P.C.B LAYOUT

注:带"\*"表示关键尺寸(9个)

NO.	PART NAME	MATERIAL	Q'TY	FINISHING	TOLERANCE UNLESS SPECIFIED	SHENZHEN XIEJIA ELECTRONICS CO.,LTD.					
8						ISSUE		DATE	DESCRIPTIONS	APPD.	
7	STEEL BALL	STEEL	1	NATURAL	WITHIN : 1.5±0.1mm OVER : 1.5±0.2mm				DRWG NO.: XJ-DR-SK62H01-00		
6	SPRING	STEEL WIRE	1	TEMPER					DWN.	ZHOUYU	2005-12-26
5	CONTACT CLIP	PBS STRIP	6	Ag PLATED					CHK'D	FANGYING	2005-12-26
4	TERMINAL	BRASS STRIP	24	Ag PLATED OVER Ni PLATED					APPD.	KANGXINAN	2005-12-26
3	BASE	PHENOLIC RESIN	1	NATURAL	TITLE : HORIZONTAL SLIDE SWITCH	UNIT : MM					
2	FRAME	STEEL STRIP	1	Ni PLATED	MODEL: SK-62H01	SCALE: 3:2					
1	KNOB	POM	1	BLACK	ALL MATERIALS MUST BE COMPLIANT TO ROHS						